



香港霧業有限公司
Hong Kong Misting Limited

吊頂/天花式抽濕機 (薄款)
**Ultra-thin Ceiling Mounted
Dehumidifier**
DE-05A



型號 Model

DE05A-28L	DE05A-40L	DE05A-60L	DE05A-100L	DE05A-140L	
DE-05A-180L	DE-05A-250L	DE-05A-380L	DE-05A-500L	DE-05A-750L	DE-05A-1000L

環保雪種
Eco-friendly
Refrigerant

紫外線殺菌燈
UV-C
Germicidal Lamp

WiFi/RS485
遠程控制
Remote Control



進入網站
了解更多

UVC
內置紫外光殺菌燈

**HEPA
Filter**

//產品特點

1. 20mm排水喉
2. 大抽濕量:28升/日 - 140升/日
3. UV-C殺菌裝置, 殺菌消毒
4. HEPA Filter
5. 底部貼有水平儀, 精度可達1%
6. 低噪音、高靜壓
7. 高效自動化霜系統
8. +/-1% 精準濕度調節
9. 24小時定時功能
10. 系統故障自動診斷功能
11. 斷電記憶功能
12. WiFi App 遠程控制
13. 全自動濕度控制系統

WiFi App 遠程控制



IOT App Control Smart Life - Smart Living

Smart Life是一款專為智慧型裝置控制和管理而設計的應用程式。這款易於使用的應用程式可協助您實現智慧型裝置互聯，讓您安心無憂地用手機APP管理智慧型設備DE05A。



//出入風設計

DE系列從房間抽出空氣並將其返回。它有一個輸入和一個輸出。它可以用於從外部供應空氣。

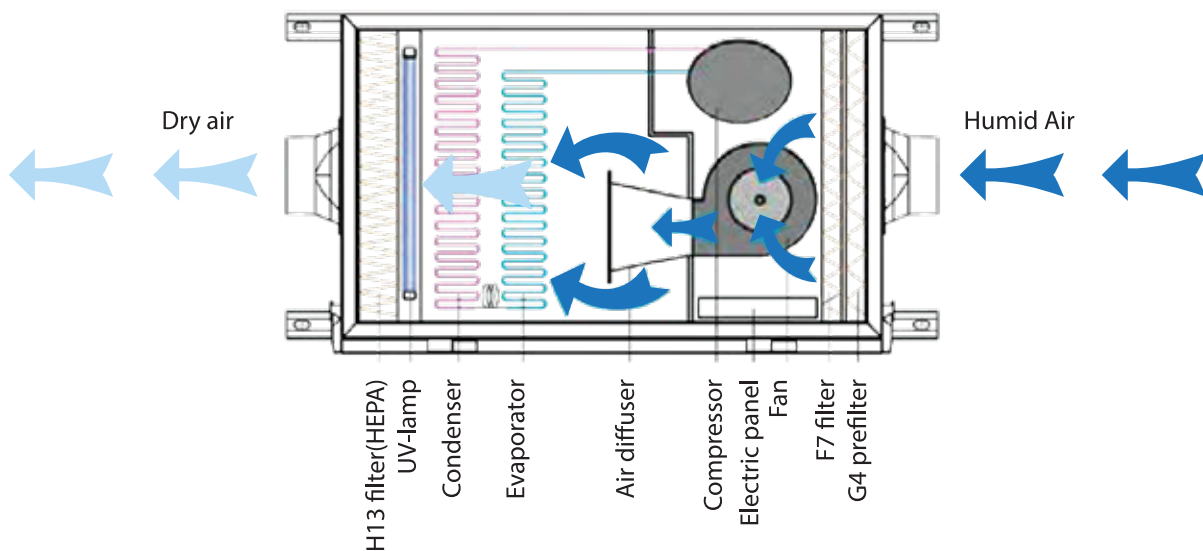

// 濾網選擇

初級濾網保護機器設備，將可以有效過濾空氣中的懸浮微粒。而高效率濾網，則可以加強保護人員呼吸系統健康。



DE05A 預設濾網

Primary + Medium effect

特點：

- 環保、無汞、無鉛、無輻射、無碳
- 有效且有效率地去除PM空氣顆粒和油顆粒



可加配:

HEPA Filter

HEPA 13+ 活性炭複合濾芯

特點：

- HEPA 濾網過濾0.3um (PM 2.5) 病毒、細菌、致敏原甚至氣溶膠*
- 活性炭有效吸附甲醛、廢氣、煙霧及異味

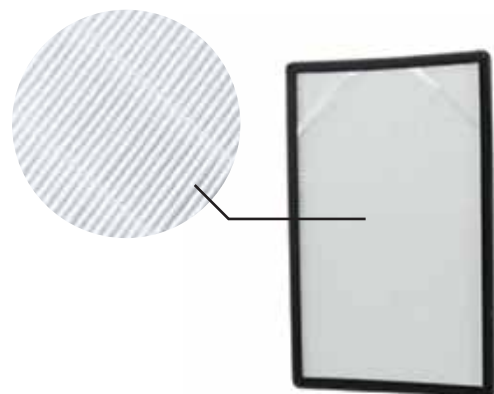

可加配:

鋁濾網 Aluminum Filter

過濾效果：金屬濾網的過濾效率高，可以有效過濾空氣中的灰塵、顆粒物、細菌、病毒等，保障空氣的潔淨度。

耐用性：金屬濾網具有良好的耐用性，可以反覆使用，節省成本。

易清潔性：金屬濾網可以用水清洗或高壓氣體清洗，清潔方便。

特點：

- 可拆式濾網，易清潔
- 摺疊式設計
- 全鋁質用料



//吊頂或天花式抽濕機主機體



厚265mm



28L/Day
40L/Day
60L/Day

厚375mm



100L/Day
140L/Day

控制

通過LCD控制面板設置濕度。亦可使用WiFi App通訊端口中央遠程控制多台抽濕機。

殺菌消毒功能

抽濕機內置UV-C紫外線殺菌燈，可直接破壞病毒細菌的DNA、RNA，達到瞬間殺菌效果。

運作音量

機身內機件採用靜音電機配合防震設計，全程寧靜運作。

產品安全性

全金屬結構機身及防火電控箱，配合鋁合金隔塵網，符合阻燃防火要求，保障用家安全。

UVC

內置紫外光殺菌燈



//產品線圖說明I

DE05A-28L

- 入風
- 出風

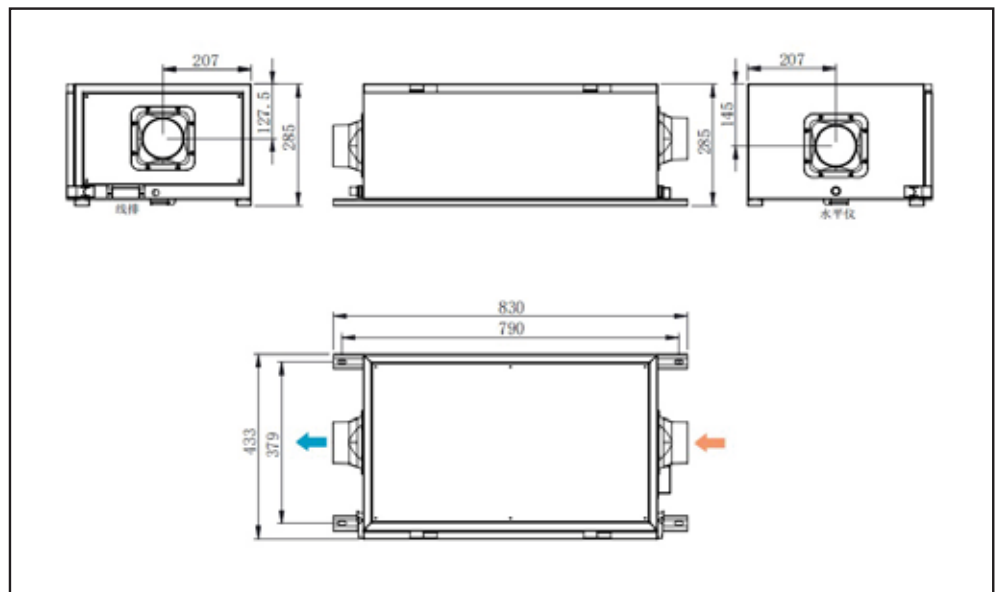

DE05A-40L

- 入風
- 出風

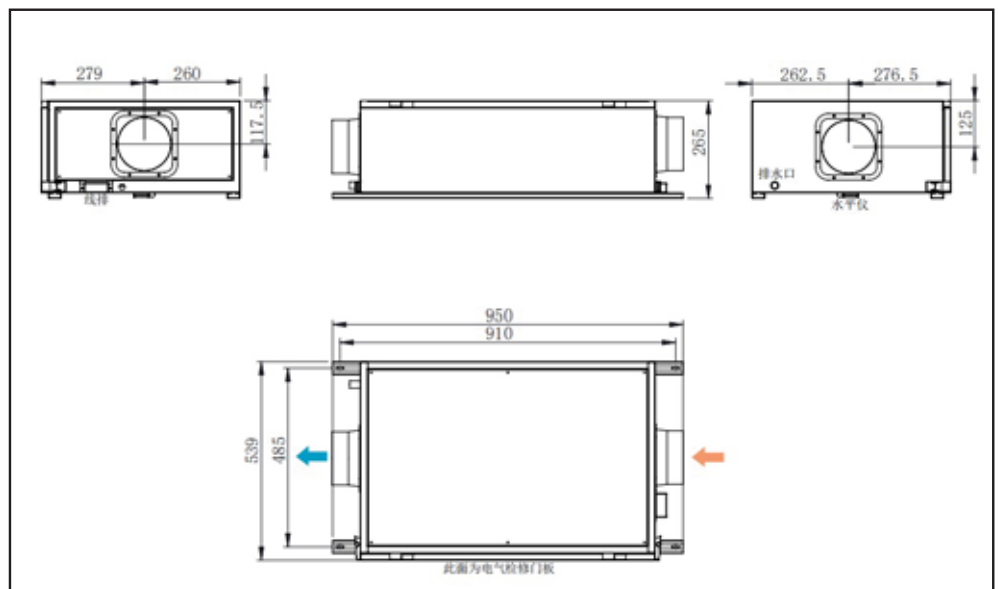

DE05A-60L

- 入風
- 出風

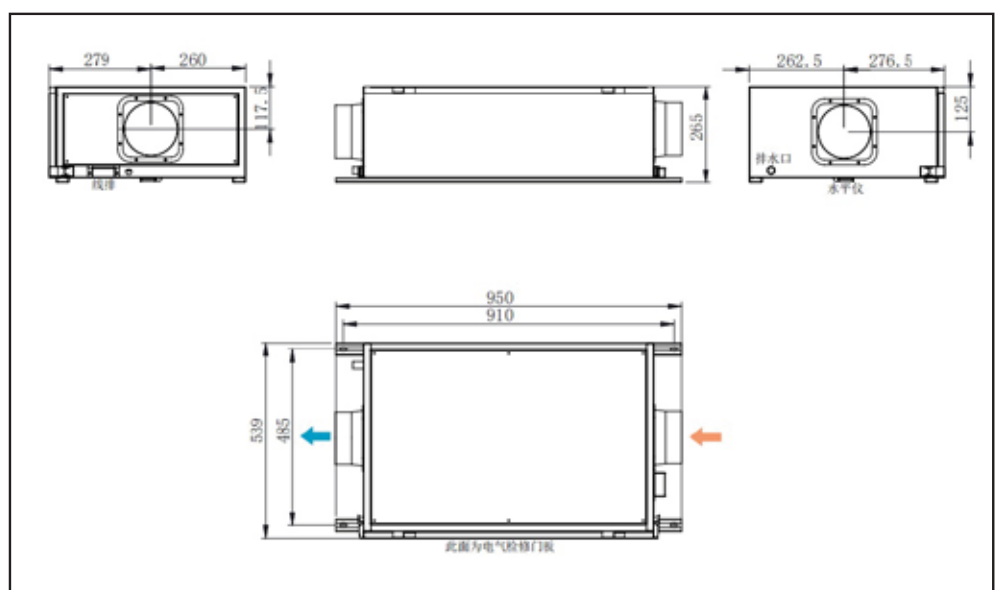

//產品線圖說明II

DE05A-100L

● 入風

● 出風

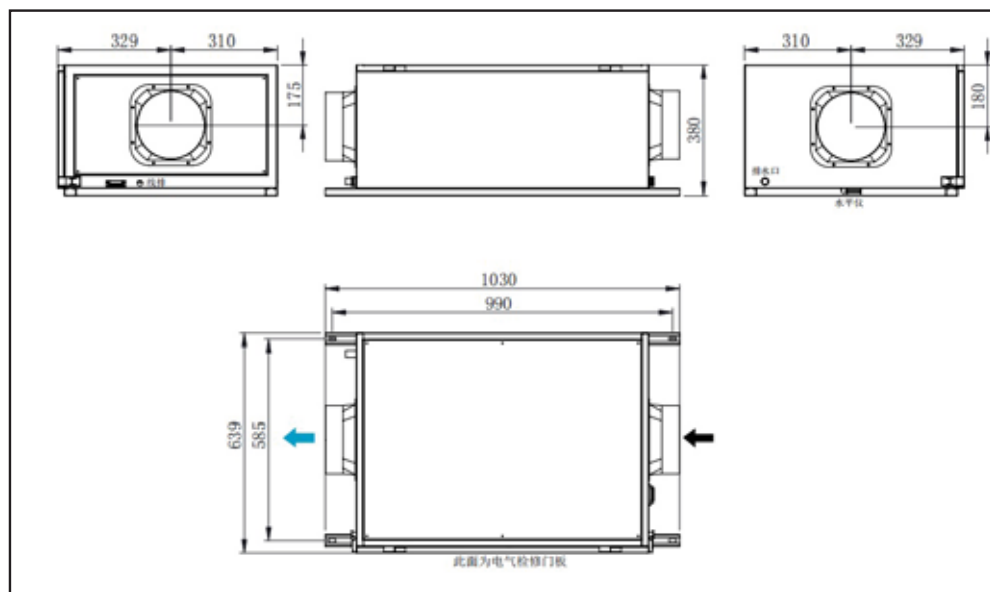

DE05A-140L

● 入風

● 出風

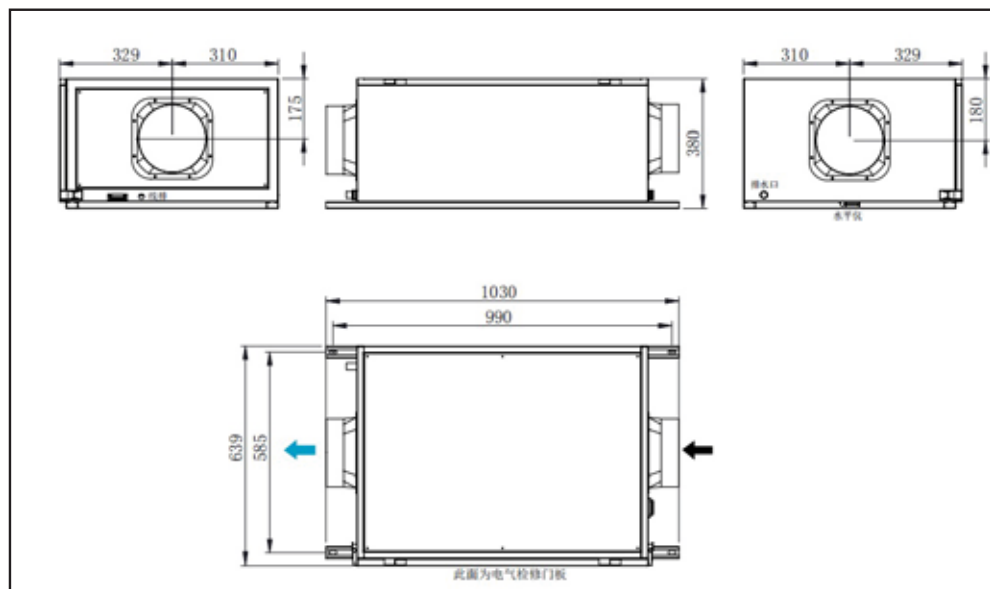

//性能參數

Model No.	Voltage	Frequency	Current	Input Power	Speed	Capacitor	Air Flow	Noise	Operating Temperature	Approvals	Cave
	V	Hz	A	W	rpm	uF	m ³ /hCFM	dB(A)	Min/Max(°C)		
DE05A	220	50	0.67	150	145	3.5	400/259	57	-30/+60	CCC CE RoHS	1
			0.55	120	1080		330/194	49			2
			0.47	100	870		240/141	43			3

特性曲線

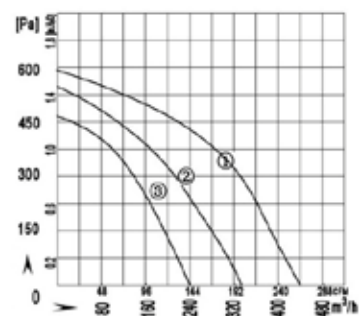

// 產品規格

主機體



控制器



DE05A-28L

DE05A-40L

Dehumidify capacity
(30°C 80%RH)

28 L/D

40 L/D

Area	20-40m ²	40-60m ²
Power supply	AC220~240V, 50Hz	AC220~240V, 50Hz
Rated input(W)	400	620
Rated current(A)	1.8	2.8
Refrigerant	R134A	R134A
Air circulation(m ³ /h)	280-350	500-670
Fan type	High/Low, stepless	High/Low, stepless
Noise level dB(A)	35	45
Operation temperature	5-35°C	5-35°C
Filtration	Primary + Medium effect+ HEPA 13	Primary + Medium effect+ HEPA 13
Purification	UV Lamp + Ioniser	UV Lamp + Ioniser
Waterproof grade	IPX3	IPX3
Seeper tray	SUS304	SUS304
Air inlet(mm)	Φ100	Φ150
Air outlet(mm)	Φ100	Φ150
Dimension D*W*H(mm)	830*433*265	950*539*265
Packing D*W*H(mm)	930*533*415	1050*639*415
Net weight(kg)	40	45

//產品規格II

DE05A-60L

DE05A-100L

DE05A-140L

Dehumidify capacity (30°C 80%RH)	60 L/D	100 L/D	140 L/D
Area	60-80m ²	90-120m ²	120-150m ²
Power supply	AC220~240V, 50Hz	AC220~240V, 50Hz	AC220~240V, 50Hz
Rated input(W)	700	920	1160
Rated current(A)	3.3	4.3	5.4
Refrigerant	R134A	R410A	R410A
Air circulation(m ³ /h)	650-780	1000-1200	1200-1350
Fan type	High/Low, stepless	High/Low, stepless	High/Low, stepless
Noise level dB(A)	45	45	45
Operation temperature	5-35°C	5-35°C	5-35°C
Filtration	Primary + Medium effect+ HEPA 13	Primary + Medium effect+ HEPA 13	Primary + Medium effect+ HEPA 13
Purification	UV Lamp + Ioniser	UV Lamp + Ioniser	UV Lamp + Ioniser
Waterproof grade	IPX3	IPX3	IPX3
Seeper tray	SUS304	SUS304	SUS304
Air inlet(mm)	Φ150	Φ200	Φ200
Air outlet(mm)	Φ150	Φ200	Φ200
Dimension D*W*H(mm)	950*539*265	1030*639*375	1030*639*375
Packing D*W*H(mm)	1050*639*415	1130**739*525	1130**739*525
Net weight(kg)	47	68	71

客戶個案分享



// 產品規格 III

主機體



DE-05A-180L

DE-05A-250L

DE-05A-380L

Dehumidify capacity (30°C 80%RH)	180 L/D	250 L/D	380 L/D
Area	200-250m ²	250-350m ²	500-600m ²
Power supply	AC380V, 50Hz	AC380V, 50Hz	AC380V, 50Hz
Rated input(W)	2700	4000	5500
Rated current(A)	4.8	7	10
Refrigerant	R410A	R410A	R410A
Air circulation(m ³ /h)	1800-2200	2500-2900	3500-3850
Fan type	High/Low, stepless	High/Low, stepless	High/Low, stepless
Noise level dB(A)	55	55	55
Operation temperature	5-35°C	5-35°C	5-35°C
Filtration	Primary + Medium effect	Primary + Medium effect	Primary + Medium effect
Purification	UV Lamp + Ioniser	UV Lamp + Ioniser	UV Lamp + Ioniser
Waterproof grade	IPX3	IPX3	IPX3
Seeper tray	SUS304	SUS304	SUS304
Air inlet(mm)	500*400	500*400	750*450
Air outlet(mm)	356*313	356*313	818*313
Dimension D*W*H(mm)	1370*820*640	1370*820*640	1370*1120*720
External static pressure	200Pa	200Pa	200Pa
Net weight(kg)	175	182	270

// 產品規格iv

主機體



DE-05A-500L

DE-05A-750L

DE-05A-1000L

Dehumidify capacity (30°C 80%RH)	500 L/D	750 L/D	1000 L/D
Area	600-700m ²	950-1050m ²	1300-1400m ²
Power supply	AC380V, 50Hz	AC380V, 50Hz	AC380V, 50Hz
Rated input(W)	9000	15000	21000
Rated current(A)	16	26	37
Refrigerant	R410A+K9	R410A	R410A
Air circulation(m ³ /h)	4800-5300	7500-9000	9000-11000
Fan type	High/Low, stepless	High/Low, stepless	High/Low, stepless
Noise level dB(A)	55	55	55
Operation temperature	5-35°C	5-35°C	5-35°C
Filtration	Primary + Medium effect	Primary + Medium effect	Primary + Medium effect
Purification	UV Lamp + Ioniser	UV Lamp + Ioniser	UV Lamp + Ioniser
Waterproof grade	IPX3	IPX3	IPX3
Seeper tray	SUS304	SUS304	SUS304
Air inlet(mm)	750*450	1200*450	1200*450
Air outlet(mm)	818*313	1058*348	1058*348
Dimension D*W*H(mm)	1370*1120*720	1700*1642*720	1700*1642*720
External static pressure	200Pa	400Pa	400Pa
Net weight(kg)	300	500	560